



CONTI+ 

**GLOBAL
MANUFACTURER OF
RELIABLE & INNOVATIVE
SHOWER ROOM
AND WASHROOM
SOLUTIONS.**



CONTI+ together with you

Drinking water hygiene &
Legionella prevention
in hospitals

08 June 2023
Chapel of the hospital
AZ Maria Middelaes
in Gent / Belgium





CONTI+ SHOWER & WASHROOM SOLUTIONS

our products

Shower solutions | Washroom solutions | Urinal flush valves |
Kitchen Faucet | Sanitary equipment & Washbasin solutions |
CONTI+ Service APP | CONTI+ CNX Water management system

with Brand values

Sustainable | Hygiene | Save | Smart |
CONTI+ Hygienekonzept zur Trinkwasserhygiene

for you

Commercial & public facilities | Semi-public & private facilities |
Healthcare & medical facilities and more



SHOWERS & WASHROOM SOLUTIONS

TECHNOLOGY AND HYGIENE PERFECTLY COMBINED

Unique, versatile, reliable and innovative: Our extensive range of electronic and mechanical shower and washbasin faucets through to urinal flush valves or the unique new Thermostat-E technology offers maximum comfort, hygiene and safety.

Our high-performance solutions open up new scope for designing contemporary, future-oriented shower and washrooms.

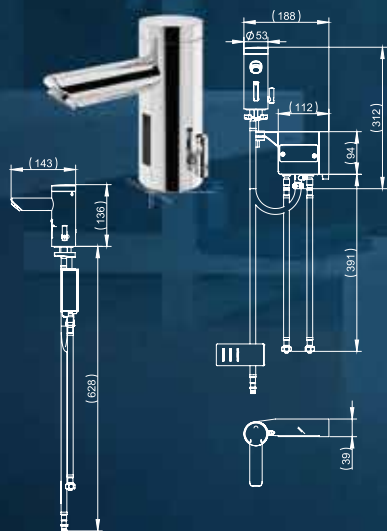

**THERMOSTAT-E & SMART CONTROL
COLD WATER FLUSH**

Showers: intelligent | versatile | connectable | electronic



Faucet: high-quality | water-saving | electronic to self-closing



Wellness solutions: Shower heads | spa & wellness up to DN20



Kneipp fittings

- Kneipp cast fittings
- Flash-cast fittings
- Concealed fittings

Special features: Decentralised water treatment & more



Service solutions

- Conversion
- Special solutions
- Object & customer service

INDIVIDUAL AND CENTRAL MANAGEMENT OF FAUCETS

APP & CNX

Hygiene requirements are increasing all the time, particularly in public, semi-public, commercial and industrial buildings – both nationally and internationally. We continually optimise our shower systems to meet these needs. Our comprehensive CONTI+ hygiene concept guarantees maximum safety in shower rooms and washrooms – for every application area. We consider the following innovative technologies and hygiene features in advance for our products:

CONTI+ HYGIENE FEATURES

- CONTI+ hygiene concept (PREVENTIVE | PERMANENT | ACUTE)
- Drinking water hygiene (3 phases for prevention, compliance and remediation)
- Saving water and energy costs
- Materials suitable for drinking water
- Non-porous and easy-to-clean surfaces
- Touchless operation
- Automatic non-contact closing function
- Keeping drinking water installations germ-free
- Retention of germs at tapping points
- Low aerosol
- Easy maintenance
- Cold water flushing, electronic
- Hygienic flushing, electronic
- Thermal disinfection, electronic, manual and with additional safety via key switch
- Documented operating and hygiene functions





CONTI+ ADAPTIVE
MULTIFUNCTIONAL
WATER PATH –
one solution –
wide-ranging fields
of application,
maximum installation
comfort and extensive
functionality transfer.



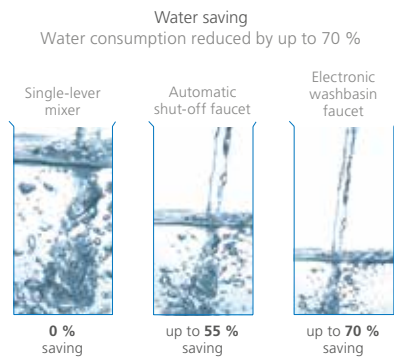

for showers, faucets, urinal flush valves & kitchen (electronic)



to meet the most demanding hygiene requirements



CONTI+ has a long history of developing smart solutions for central management, control and monitoring of devices and components for shower systems.

From individual faucets to complete systems with up to 150 CONTI+ faucets, our intelligent technologies allow very easy and reliable management of all operating, documentation and safety functions, such as convenient automation of rinses, setting operating periods for thermal disinfection and setting operation stops or cleaning stops. This ensures more comfort and outstanding hygiene.

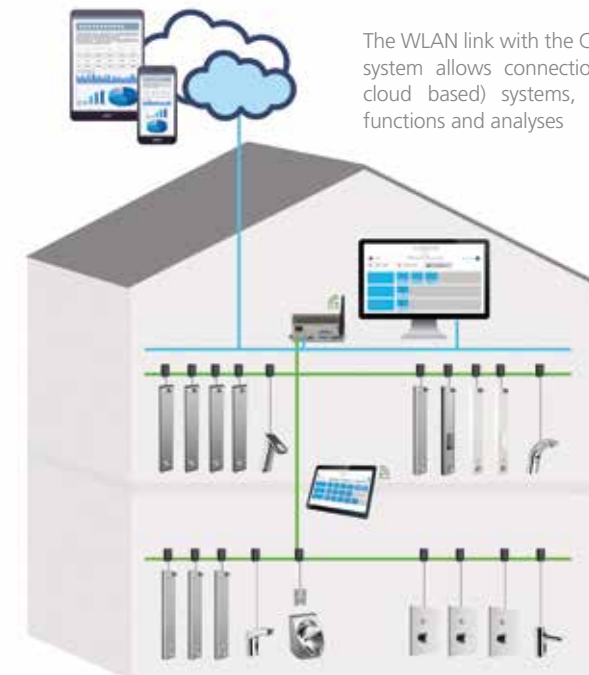

The WLAN link with the CNX water management system allows connection to higher-level (e.g. cloud based) systems, as well as additional functions and analyses

Your CONTI+ Partner

Alexander Matt

International Sales Director

Direct: +49 641 98221 15

Mobile: +49 151 50241009

E-Mail: alexander.matt@conti.plus



CONTI Sanitärarmaturen GmbH
Hauptstraße 98
35435 Wettenberg | Germany
Phone +49 641 98221 0
Fax +49 641 98221 50
info@conti.plus
www.conti.plus

Member of Fortuna Group 